

AUTOMATIC OFF-LINE STRAPPING MACHINE

MODEL: MB -1

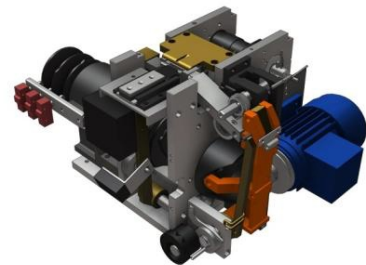

A Robust designed model for standalone strapping machine for PP strap varying from 9 to 15 mm width and offer best cost performance ratio.



Main Features

1. Robust and reliable strapping head
2. Faster response time and strapping speed
3. User friendly adjustment and operation
4. Separate tool kit for easy maintenance
5. Heavy duty heater



Benefits

1. Easy loading and unloading of strap
2. Caster wheels for easy shop floor movement
3. Low maintenance cost
4. Tension controller inside the machine
5. Smoke exhaust system

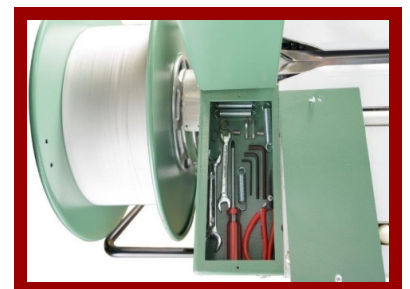

Specifications and options

1. Various Operating Method: Three ways to operate the machine: Start button, table top switch and foot pedal switch.
2. Optional Ball Table Top for product weight more than 40 KG
3. Optional auto strap feeding mechanism

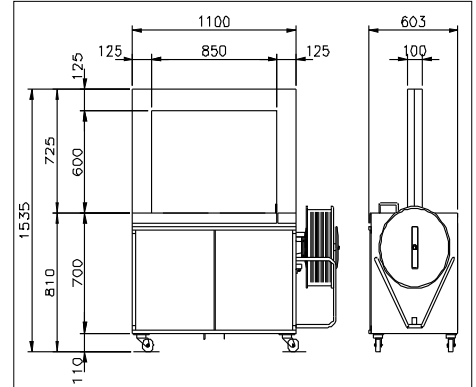

Power Supply	:	Three Phase, 415±5%V, 50Hz
CSM belt speed	:	20 Meters/min
Tape Size	:	2", 2 ½" or 3"
P.P Strap Width	:	9 / 12 / 15 mm
Strapping Tension	:	0.5 to 70 Kgs
Strapping Speed	:	2.2 sec/per cycle; 1500cycle/per hour
Min Pack Size	:	300 (L) x 200 (W) x 150 (H) (mm)
Max. Package Size	:	700 (L) x 500(W) x 500 (H) (mm)
Carton Weight	:	5 to 40 Kg
Working Height	:	810 (mm)
System Size (LxWxH)	:	1652 (L) x 1440 (W) x 1715 (mm)
.Power Consumption	:	1.22 KW

Available Arch Sizes

W \ H	650	850	1050	1250	1450	1650	1850	2050	..
400	*	*	*	*	*	*	☆	☆	..
600	*	S	*	*	*	*	☆	☆	..
800	*	*	*	*	*	☆	☆	☆	..
1000	*	*	*	*	☆	☆	☆	☆	..
1200	*	*	*	☆	☆	☆	☆	☆	..
1400	*	*	☆	☆	☆	☆	☆	☆	..
1600	☆	☆	☆	☆	☆	☆	☆	☆	..
1800	☆	☆	☆	☆	☆	☆	☆	☆	..
2000	☆	☆	☆	☆	☆	☆	☆	☆	..
2200	☆	☆	☆	☆	☆	☆	☆	☆	..
2400	☆	☆	☆	☆	☆	☆	☆	☆	..
.	☆	☆	☆	☆	☆	☆	☆	☆	..

- S :The standard model
 * :Made to order
 ☆ : Made to order. The arch motor is required

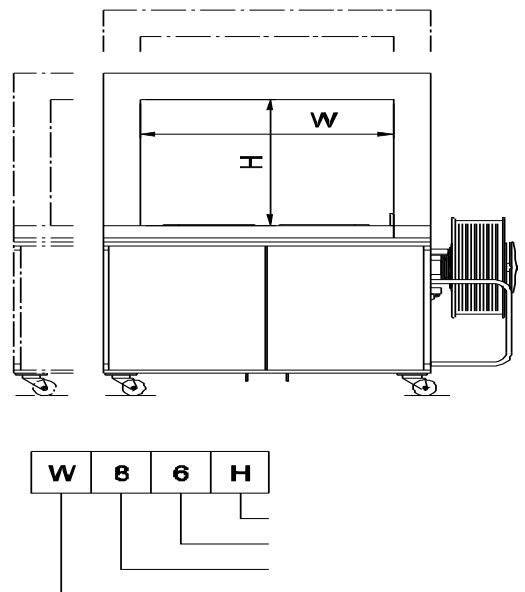

Signode India Limited
 Email: info@signodeindia.com
 URL: www.signodeindia.com